

Zweihand-Blindnietmuttern und -schrauben Ratsche

Two hand operating tool for blind rivet nuts and bolts ratchet-system

Pince à riveter à cliquet pour écrous et goujons

GO-12-N (Set)



Arbeitsbereich / Capacity / Utilisation
GO-NUT M5- M12 / GO-BOLT M5 - M8

alle Materialien
all materials
pour tout matériau

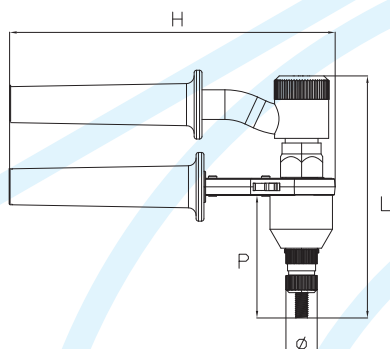

Gewicht	Weight	Poids	1,00 kg
L x H	L x H	L x H	160 x 200 mm
Mundstücktiefe P	Mouth piece deep P	Profondeur du nez P	80 mm
Mundstückaufnahme	Mouth piece adapter	Positionneur des embouts	Ø 20 mm
Material Gehäuse	Body material	Matériau du corps	nylon /steel
Material Hebel	Lever material	Matériau des leviers	steel
Ausrüstung	Equipment	Équipement	GO-NUT 1 x M5 - M12 GO-BOLT 1 x M5 - M8



GO-12-N (Set)

KG	L	H	W	CODE	€
3,65	370 mm	80 mm	270 mm	22440 00019	235,00

SET INCL. GO-NUT ST					
30 x	30 x	15 x	10 x	5 x	30 x
M5	M6	M8	M10	M12	M6